

# OPEL COMBO PRICES/OPTIONS

2018 models. Prices effective 1 September 2017



# COMBO PRICES

Trim	Engine	Transmission	CO <sub>2</sub> (g/km)	GVW (kg)	Payload (kg)	RRP inc. VAT & VRT €
<b>PANEL VAN</b>						
2000 L1 H1	1.3CDTi (95PS)	Manual	133	2040	740	16,060
2000 L1 H1	1.6CDTi (105PS)	Manual	134	2098	768	17,985
2000 L1 H1 Sportive	1.3CDTi (95PS)	Manual	133	2040	695	17,310
2000 L1 H1 Sportive	1.6CDTi (105PS) Start/Stop	Manual	120	2098	723	19,730
2300 L1 H1	1.3CDTi (95PS)	Manual	133	2320	990	16,360
2300 L1 H1	1.6CDTi (105PS)	Manual	135	2418	1018	18,285
2300 L1 H1 Sportive	1.3CDTi (95PS)	Manual	133	2320	945	17,610
2300 L1 H1 Sportive	1.6CDTi (105PS) Start/Stop	Manual	121	2418	973	20,030
2000 L1 H2	1.6CDTi (105PS) Start/Stop	Manual	131	2120	740	19,480
2300 L1 H2	1.6CDTi (105PS) Start/Stop	Manual	131	2428	1018	19,780
2000 L1 H2 Sportive	1.6CDTi (105PS) Start/Stop	Manual	131	2120	695	20,730
2300 L1 H2 Sportive	1.6CDTi (105PS) Start/Stop	Manual	131	2428	973	21,030
2300 L2 H1	1.3CDTi (95PS)	Manual	136	2385	990	17,410
2300 L2 H1	1.6CDTi (105PS)	Manual	135	2458	1018	18,785
2300 L2 H1 Sportive	1.3CDTi (95PS)	Manual	136	2385	960	18,660
2300 L2 H1 Sportive	1.6CDTi (105PS) Start/Stop	Manual	121	2458	988	20,530
2300 L2 H2	1.6CDTi (105PS) Start/Stop	Manual	133	2488	1018	20,280
<b>GLAZED CREW VAN</b>						
2300 L1 H1	1.3CDTi (95PS)	Manual	136	2234	764	20,195
2300 L2 H1	1.3CDTi (95PS)	Manual	136	2254	764	21,695
2300 L2 H1	1.6CDTi (105PS) Start/Stop	Manual	125	2349	764	23,515

The above is for information purposes only as our products are continually updated and changes may be made to the specifications at any time. If you require any specific feature, you must consult your authorised Opel Dealer who is regularly updated with any change in specification. Specifications are subject to change without notice.

RRP does not include recommended delivery charge of €700. This price includes the recommended cost of PDI, number plates and delivery to an Opel Dealer. The recommended delivery charge does not include fuel supplied by the dealer, Motor insurance or any other goods or services supplied by agreement between the Dealer and the customer.

Prices effective 1.9.2017. Prices subject to alteration or change without notice or obligation.

# EQUIPMENT

Recommended Retail Prices including Taxes

## SAFETY

**Standard features** • Electronic Stability Programme (ESP) with hill start assist and anti-slip regulator traction control • Daytime running lights • Anti-lock Braking System (ABS) with electronic brakeforce distribution • Emergency brake assist • Driver's airbag • Height-adjustable head restraints • Height-adjustable front seatbelts • Inertia-reel lap and diagonal seatbelts • Seatbelt pretensioner system • Front seatbelt force limiters • Side-impact protection beams • Laminated windscreen • Fire prevention system with fuel cut-off • Centre brake light

Additional features	Combo		Combo Crew Van
	Panel Van	Sportive	
Front passengers' airbag with deactivation switch	<input type="radio"/> €224	<input type="radio"/> €224	<input type="radio"/> €254
Front passenger's airbag with driver and passenger's side-impact airbags	<input type="radio"/> €305	<input type="radio"/> €305	<input type="radio"/> €346
Active-safety head restraints (front seats only)	<input type="radio"/> €52	<input type="radio"/> €52	<input type="radio"/> €59

## SECURITY

**Standard features** • Remote control central deadlocking • Electronic engine deadlock immobiliser • Electronic theft protection for audio equipment • 'Key left in ignition' audible warning • Lockable glovebox • Lockable fuel filler cap

Additional features	Combo		Combo Crew Van
	Panel Van	Sportive	
Alarm pre-installation kit	<input type="radio"/> €62	<input type="radio"/> €62	<input type="radio"/> €70
Third key	<input type="radio"/> €77	<input type="radio"/> €77	<input type="radio"/> €87
Third key with remote control	<input type="radio"/> €103	<input type="radio"/> €103	

## FACIA, INSTRUMENTS AND CONTROLS

**Standard features** • Trip computer, provides information on overall distance, trip distance, average and instantaneous fuel consumption, remaining range, distance and average speed since last reset • Trip odometer • Rev counter • Electronically controlled coolant temperature gauge and fuel gauge with low fuel level warning light • Service-due indicator • Gearshift indication light • 12-volt accessory socket • Digital clock • Reach and rake-adjustable steering column • Lidded glovebox • Dipping rear-view mirror (when glazed bulkhead and glazed rear doors/tailgate are specified) • Storage compartment on driver's side facia

Additional features	Combo		Combo Crew Van
	Panel Van	Sportive	
Cruise control	<input type="radio"/> €153	<input type="radio"/> €153	<input type="radio"/> €173
Leather-covered steering wheel	<input type="checkbox"/>	<input type="checkbox"/>	<input type="checkbox"/>
Leather-covered gear knob	<input type="checkbox"/>	<input type="checkbox"/>	<input type="checkbox"/>

= Optional at extra cost.  = Only available as part of an extra-cost option pack.

# EQUIPMENT

Recommended Retail Prices including Taxes

## SEATING

**Standard features** • Cube cloth seat trim • Reach and rake-adjustable driver and front passenger's seat

Additional features	Combo		Combo Crew Van
	Panel Van	Sportive	
Vinyl seat trim <sup>1</sup>	○ €52		
Height-adjustable driver's seat with armrest and lumbar support	○ <sup>1</sup> €103	●	○ €116
Front passenger's seat with under cushion storage compartment	○ <sup>1</sup> €32	○ €32	
Rear seat with 'fold and tumble' facility and 60/40 split seat back and cushion			●

## AUDIO, COMMUNICATION AND NAVIGATION

Features	Combo		Combo Crew Van
	Combo	Sportive	
<b>Driver Pack</b> • CD/MP3 CD player/stereo radio/Bluetooth® connectivity for compatible mobile phones/aux-in socket/USB connectivity/RDS with Traffic Programme/steering wheel mounted audio controls • Leather-covered steering wheel • Leather-covered gear knob • Pre-installation for TomTom navigation system (excludes satellite navigation)	○ €558	○ €558	○ €633
<b>CD player/stereo radio</b> • CD player • AM/FM stereo radio with 24 station presets • RDS with Traffic Programme • 20 watts per channel output • 4 speakers	●	●	●
<b>CD 50 multimedia</b> • CD/MP3 CD player • Bluetooth® connectivity for compatible mobile phones • Aux-in socket • USB connectivity • AM/FM stereo radio with 24 station presets • RDS with Traffic Programme • Steering wheel mounted audio controls • 20 watts per channel output • 4 speakers	○ €450	○ €450	○ €511
Pre-installation for TomTom navigation system (excludes satellite navigation)	□	□	□
Flexible roof-mounted aerial	●	●	●

## INTERIOR

**Standard features** • Cabin interior courtesy light operated by door switches • Four-speed air blend heater • Two coat hooks • Door armrests • Overhead shelf (H2 models) • Door storage pockets • Twin sunvisors, front passenger's with vanity mirror • Vinyl floor covering in cabin area • Passenger assist handle

Additional features	Combo		Combo Crew Van
	Panel Van	Sportive	
Air conditioning	○ €861	●	○ €977
Electronic climate control incorporating air conditioning (mandates electrically adjustable / heated door mirrors with exterior temperature sensor at extra cost)		○ €1008	
Overhead shelf	○ €30	●	●
Soundproofed bulkhead		●	
<b>Smoker Pack</b> • Cigar lighter • Removable ashtray	○ €67	○ €67	○ €76

● = Standard equipment. ○ = Optional at extra cost. □ = Only available as part of an extra-cost option pack.

<sup>1</sup> = Vinyl seat trim is not available in conjunction with height-adjustable driver's seat or front passenger's seat with under cushion storage.

# EQUIPMENT

Recommended Retail Prices including Taxes

## MECHANICAL

**Standard features** • Front-wheel drive • Five-speed manual gearbox (1.3CDTi) • Six-speed manual gearbox (1.6CDTi/2.0CDTi) • Electric power-assisted steering

Additional feature	Combo		Combo Crew Van
	Panel Van	Sportive	
Up-rated alternator	○ €103	○ €103	○ €116

## EXTERIOR

Additional features	Combo		Combo Crew Van
	Panel Van	Sportive	
<b>Winter Pack</b> • Headlight washers • Front fog lights • Exterior temperature sensor • Electrically adjustable/heated door mirrors		○ €356	
Front fog lights	○ €137	○ €137	○ €155
Electrically adjustable/heated door mirrors	○ €103	○ €103	○ €116
Electrically adjustable / heated door mirrors with exterior temperature sensor	○ €153	○ €153	○ €172
Rear parking distance sensors	○ €305	○ €305	○ €346
Roof rails (H1 models only) <sup>2</sup>	○ €179	○ €179	
Body-colour bumpers and exterior door mirrors		●	
Body-colour bumpers	○ €200		
Brilliant paint (Tomato Red)	○ €155	N/C	○ €175
Two-coat metallic paint (Magnetic Silver, Ruby Red, Twilight Blue, Marine Blue, Midnight Black, Pepperdust)	○ €600	N/C	○ €681

## WHEELS AND TYRES

Features	Combo		Combo Crew Van
	Panel Van	Sportive	
15-inch steel wheels with centre covers and 185/65 R 15 tyres (2000 models)	●		
16-inch steel wheels with centre covers and 195/60 R 16 tyres (2300 models)	●		
15-inch steel wheels with full-diameter wheel trims and 185/65 R 15 tyres (1.3CDTi/1.6CDTi 2000 models)		●	
16-inch steel wheels with full-diameter wheel trims and 195/60 R 16 tyres (2.0CDTi/2300 models)		●	●
16-inch alloy wheels with 195/60 R 16 tyres		○ €608	
Winter tyres – Goodyear Ultragrip-7 195/65 R 15 (2000 models) or 195/60 R 16 (2300 models)	○ €275	○ €275	○ €312
Tyre inflation kit	●	●	●
Full-size spare wheel (in lieu of tyre inflation kit)	○ €153	○ €153	○ €173

● = Standard equipment. ○ = Optional at extra cost. N/C = No-cost option.

<sup>2</sup> = Not available with rear roof flap.

# EQUIPMENT

Recommended Retail Prices including Taxes

## LOAD AREA

**Standard features** • Load restraint lashing eyes (six) • Illuminated load area

	Combo		Combo Crew Van
	Panel Van	Sportive	
<b>Additional features</b>			
<b>Load Compartment Pack</b> • Overhead shelf • PVC load floor covering • 12-volt accessory socket in load area • Removable load area courtesy light	○ €153		
Full-height steel bulkhead	●	●	
Full-height steel bulkhead with window <sup>3</sup>	○ €52	○ €52	
Protective ladder frame behind drive (behind second-row seats on Crew Van) <sup>4</sup>	N/C <sup>5</sup>		N/C
PVC load floor covering	○ €50	●	
Nearside sliding side-access door (standard on L2 models)	○ €356	●	
Offside sliding side-access door (standard on L2 models)		○ €356	
Nearside and offside sliding side-access doors (standard on L2 models)	○ €712		
Sliding windows in nearside and offside sliding side-access doors			●
Fixed windows in nearside sliding side-access door and opposite panel/door	○ €812	○ €812	
Unglazed asymmetric rear doors (90°/180°)	●	●	
Glazed asymmetric rear doors with heated windows and wash/wipe facility <sup>7</sup>	○ €254	○ €254	○ €288
Glazed tailgate with heated window and wash/wipe facility (H1 models) <sup>7</sup>	○ €204	○ €204	●
Rear roof flap (L1 H1 models only) <sup>5,8</sup>	○ €558	○ €558	
Internal ladder storage bars <sup>9</sup>	○ €229	○ €229	

● = Standard equipment. ○ = Optional at extra cost. N/C = No-cost option.

<sup>3</sup> = Only available when glazed rear doors or tailgate are specified. <sup>4</sup> = In lieu of full-height steel bulkhead on Panel van. <sup>5</sup> = Only available with Load Compartment Pack. <sup>6</sup> = The glazed crew van is not pre-approved for VAT reclaimable status and it is advisable that customers consult their local Traffic Office for further details. <sup>7</sup> = Only available when full-height steel bulkhead with window is specified. <sup>8</sup> = Not available with roof rails, glazed tailgate or full-size spare wheel. <sup>9</sup> = Not available with Load Compartment Pack or rear roof flap.

# TECHNICAL DATA

## DIESEL ENGINES

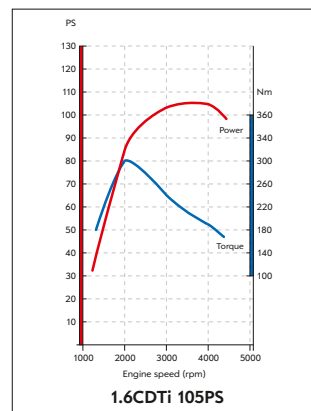
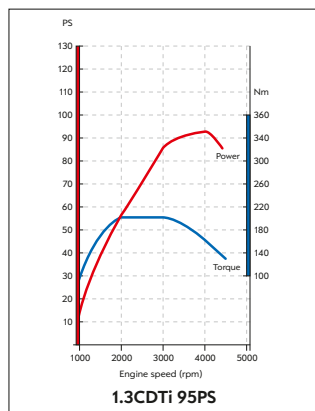

	<b>1.3CDTi (95PS)</b>	<b>1.6CDTi (105PS) with Start/Stop</b>
Capacity	1248cc	1598cc
Maximum power	95PS (70kW) @ 3500-3750rpm	105PS (77kW) @ 3500rpm
Maximum torque	200Nm (148 lb.ft.) @ 1500rpm	300Nm (221 lb.ft.) @ 1750-2000rpm
Configuration	4 cylinders, 4 valves per cylinder, double overhead camshafts	
Fuel/induction system	Turbocharger with intercooler. Common rail fuel injection	
Emissions compliance	Euro 6	
Service intervals	30,000km or two years (whichever occurs sooner)	

# TECHNICAL DATA

## Warranties\*

Every new Combo comes with:

- A three-year/150,000km manufacturer's warranty
- Opel Assistance for 12 months from first registration
- 12-year body panel anti-perforation warranty

\* = Warranty is only available on vehicles sourced from authorised Opel Ireland dealers. Terms and conditions apply – please see your Opel dealer for details.

## Transmissions

- Front-wheel drive
- 1.3CDTi: Five-speed manual
- 1.6CDTi: Six-speed manual

## Steering

- Hydraulic power-assisted rack and pinion system
- Energy-absorbing steering column
- Kerb-to-kerb turning circle:
  - L1: 11.3m (36.7ft.)
  - L2: 12.5m (41.0ft.)

## Suspension

**Front:** Independent lightweight MacPherson struts with coil springs, gas-pressure dampers and anti-roll bar.

**Rear:** Independent bi-link with coil springs, gas-pressure dampers and anti-roll bar.

## Electrics

### Alternator:

- 1.3CDTi: 105A
- 1.6CDTi: 100A
- Models with air conditioning: 120A

### Maintenance-free battery:

- 1.3CDTi: 63Ah
- 1.6CDTi/2.0CDTi: 72Ah

## Brakes

- Electronic Stability Programme (ESP)
- Hill start assist
- Traction control
- Anti-lock Braking System (ABS) with electronic brakeforce distribution

### Front ventilated disc brakes:

- 2000 models: 284mm diameter
- 2300 models: 305mm diameter

### Rear self-adjusting drum brakes:

- 1.3CDTi/1.6CDTi: 228mm diameter

## Fuel tank capacity

60 litres (13.2 gallons).

## Body



- Six-year body panel anti-perforation warranty
- Galvanised body panels
- Anti stone-chip mastic coating on sills
- Flush-fitted windscreen and rear door glass (when specified)
- Detachable front towing eye
- Rear towing eye

## FUEL ECONOMY AND EMISSIONS (ALL MODELS)

	Fuel economy litres/100km <sup>#</sup>			CO <sub>2</sub> emissions g/km <sup>#</sup>
	Urban driving	Extra-urban driving	Combined figure	
<b>L1 H1 Panel Van</b>				
2000 1.3CDTi (95PS)	6.5	4.2	5.0	133
2000 1.6CDTi (105PS)	6.3	4.4	5.1	134
2000 1.6CDTi (105PS) Start/Stop	5.3	4.1	4.5	120
2300 1.3CDTi (95PS)	6.5	4.2	5.0	133
2300 1.6CDTi (105PS)	6.5	4.4	5.2	135
2300 1.6CDTi (105PS) Start/Stop	5.3	4.2	4.6	121
<b>L1 H1 Glazed Crew Van</b>				
2300 1.3CDTi (95PS)	6.6	4.3	5.1	136
<b>L1 H2 Panel Van</b>				
2000 1.6CDTi (105PS) Start/Stop	5.3	4.7	4.9	131
2300 1.6CDTi (105PS) Start/Stop	5.3	4.7	4.9	131
<b>L2 H1 Panel Van</b>				
2300 1.3CDTi (95PS)	6.6	4.3	5.1	136
2300 1.6CDTi (105PS)	6.5	4.4	5.2	135
2300 1.6CDTi (105PS) Start/Stop	5.3	4.2	4.6	121
<b>L2 H1 Glazed Crew Van</b>				
2300 1.3CDTi (95PS)	6.6	4.3	5.1	136
2300 1.6CDTi (105PS) Start/Stop	5.3	4.4	4.7	125
<b>L2 H2 Panel Van</b>				
2300 1.6CDTi (105PS) Start/Stop	5.6	4.7	5.0	133

# = Fuel consumption information is official government environmental data, tested in accordance with the relevant EU directive. Official EU-regulated test data is provided for comparison purposes and actual performance will depend on driving style, road conditions and other non-technical factors.

## TYRE RATINGS

Tyre size	Fuel efficiency group	Wet grip performance	External noise	
			Measured (dB)	Group
185/65 R 15	C-E	A-C	68-69	
195/65 R 15	C-E	C-E	68-71	
195/60 R 16	C-E	B-C	70-72	

Tyre rating according to EU Regulation 1222/2009



# L1 H1 PANEL VAN

## EXTERIOR DIMENSIONS MM (INCHES)

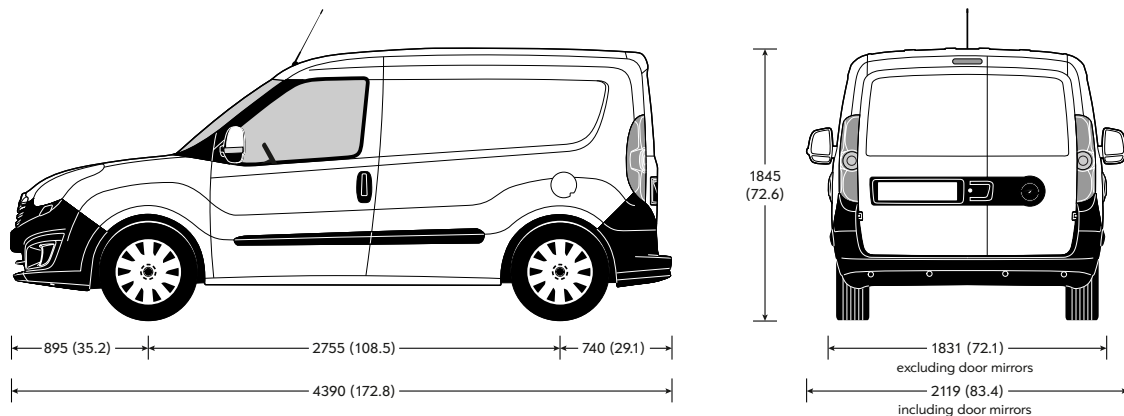

Height shown unladen.

## LOADSPACE DIMENSIONS MM (INCHES)

### Maximum load length

Panel Van	1820 (71.7)
-----------	-------------

### Maximum load width

At widest point	1714 (67.5)
-----------------	-------------

Between wheel arches	1230 (48.4)
----------------------	-------------

### Maximum load height

Maximum height	1305 (51.4)
----------------	-------------

### Rear and side load door(s)

Rear door aperture height	1250 (49.2)
---------------------------	-------------

Rear door aperture width	1231 (48.5)
--------------------------	-------------

Side door aperture height	1175 (46.2)
---------------------------	-------------

Side door aperture width	700 (27.5)
--------------------------	------------

### Loading height

Unladen	545 (21.4)
---------	------------

## LOADSPACE VOLUMES CU.M (CU.FT.)

Panel Van	3.4 (121)
-----------	-----------

## WEIGHTS AND TOWING DATA

### Plated weights and kerbweight kg

	Front axle Plated	Rear axle Plated	Total		Payload kg	Towing weights Trailer with brakes (without brakes) kg	Plated Gross Combination Weights (GCW) kg
			GVW	Minimum Mass			
<b>L1 H1 Panel Van</b>							
2000 1.3CDTi (95PS)	1090	1140	2040	1365	740	1000 (500)	3040
2000 1.6CDTi (105PS)	1090	1140	2098	1395	768	1300 (500)	3398
2300 1.3CDTi (95PS)	1090	1450	2320	1395	990	1000 (500)	3320
2300 1.6CDTi (105PS)	1200	1450	2418	1465	1018	1300 (500)	3500

**Note:** Minimum Mass ('Mass in running order' on Certificate of Conformity and 'Mass in Service' on V5C form) is defined according to European Type Approval and include all fluids, tools, 90% fuel load and driver (75kg). It is minimum mass for this variant and does not consider local specification/trim. Weights are also subject to manufacturing tolerances (EU Legislation allows 5% tolerance). **Payload** figures do not allow for the weight of the driver, or any passengers, which should therefore be deducted from the figures shown. UK and Ireland Specification adds radio and deadlocks to base vehicle adding 10kg. Sportive specification adds a further 45kg to Sportive L1 Panel Van and 30kg to Sportive L2 Panel Van. **Gross plated weights** (including axle weights) quoted on the vehicle plate are to UK and Ireland plated weight specification and must never be exceeded. **Roof load** should not exceed 100kg on H1 models including the weight of the roof rack/carrier. H2 models are not permitted to carry roof loads.

# L1 H1 GLAZED CREW VAN

## EXTERIOR DIMENSIONS MM (INCHES)

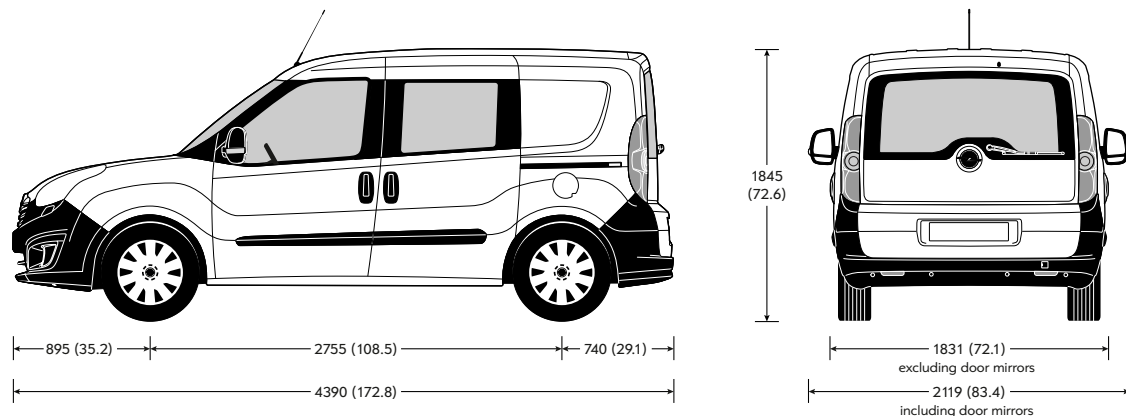

Height shown unladen.

## LOADSPACE DIMENSIONS MM (INCHES)

### Maximum load length

Crew Van with seats up	991 (39.0)
Crew Van with seats down	1400 (55.1)

### Maximum load width

At widest point	1714 (67.5)
Between wheel arches	1230 (48.4)

### Maximum load height

Maximum height	1305 (51.4)
----------------	-------------

### Rear and side load door(s)

Rear door aperture height	1250 (49.2)
Rear door aperture width	1231 (48.5)
Side door aperture height	1175 (46.2)
Side door aperture width	700 (27.5)

### Loading height

Unladen	545 (21.4)
---------	------------

## LOADSPACE VOLUMES CU.M (CU.FT.)

Crew Van with seats up (to top of seats)	0.8 (28.2)
Crew Van with seats up (to roof)	1.4 (49.4)

## WEIGHTS AND TOWING DATA

### Plated weights and kerbweight kg

	Front axle Plated	Rear axle Plated	Total		Payload kg	Towing weights Trailer with brakes (without brakes) kg	Plated Gross Combination Weights (GCW) kg
			GVW	Minimum Mass			
<b>L1 H1 Glazed Crew Van</b>							
2300 1.3CDTi (95PS)	1090	1310	2234	1485	764	1000 (500)	3234

**Note: Minimum Mass** ('Mass in running order' on Certificate of Conformity and 'Mass in Service' on V5C form) is defined according to European Type Approval and include all fluids, tools, 90% fuel load and driver (75kg). It is minimum mass for this variant and does not consider local specification/trim. Weights are also subject to manufacturing tolerances (EU Legislation allows 5% tolerance). **Payload** figures do not allow for the weight of the driver, or any passengers, which should therefore be deducted from the figures shown. UK and Ireland Specification adds radio and deadlocks to base vehicle adding 10kg. Sportive specification adds a further 45kg to Sportive L1 Panel Van and 30kg to Sportive L2 Panel Van. **Gross plated weights** (including axle weights) quoted on the vehicle plate are to UK and Ireland plated weight specification and must never be exceeded. **Roof load** should not exceed 100kg on H1 models including the weight of the roof rack/carrier. H2 models are not permitted to carry roof loads.

# L1 H2 PANEL VAN

## EXTERIOR DIMENSIONS MM (INCHES)

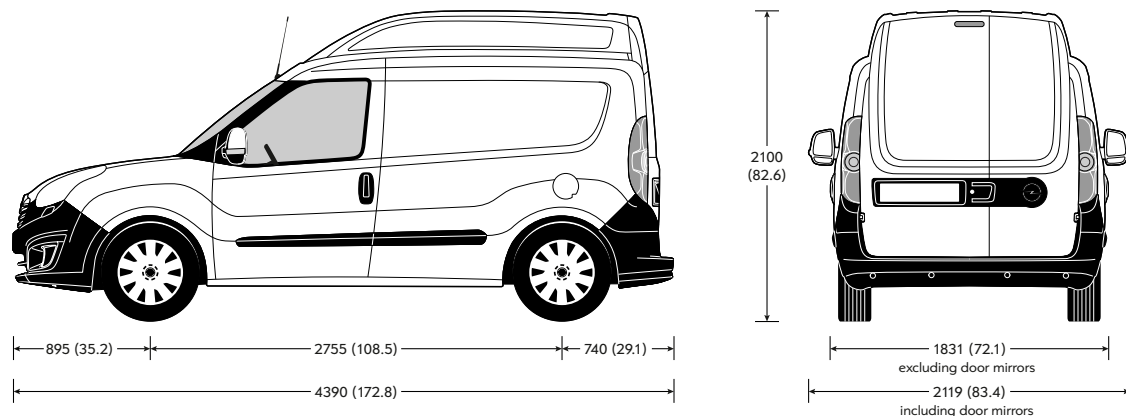

Height shown unladen.

## LOADSPACE DIMENSIONS MM (INCHES)

### Maximum load length

Panel Van	1820 (71.7)
-----------	-------------

### Maximum load width

At widest point	1714 (67.5)
-----------------	-------------

Between wheel arches	1230 (48.4)
----------------------	-------------

### Maximum load height

Maximum height	1550 (61.0)
----------------	-------------

### Rear and side load door(s)

Rear door aperture height	1455 (57.2)
---------------------------	-------------

Rear door aperture width	1231 (48.5)
--------------------------	-------------

Side door aperture height	1175 (46.2)
---------------------------	-------------

Side door aperture width	700 (27.5)
--------------------------	------------

### Loading height

Unladen	545 (21.4)
---------	------------

## LOADSPACE VOLUMES CU.M (CU.FT.)

Panel Van	4.0 (141)
-----------	-----------

## WEIGHTS AND TOWING DATA

### Plated weights and kerbweight kg

	Front axle Plated	Rear axle Plated	Total		Payload kg	Towing weights Trailer with brakes (without brakes) kg	Plated Gross Combination Weights (GCW) kg
			GVW	Minimum Mass			
<b>L1 H2 Panel Van</b>							
2000 1.6CDTi (105PS) Start/Stop	1090	1140	2120	1445	740	1300 (500)	3420
2300 1.6CDTi (105PS) Start/Stop	1200	1450	2428	1475	1018	1300 (500)	3500

**Note: Minimum Mass** ('Mass in running order' on Certificate of Conformity and 'Mass in Service' on V5C form) is defined according to European Type Approval and include all fluids, tools, 90% fuel load and driver (75kg). It is minimum mass for this variant and does not consider local specification/trim. Weights are also subject to manufacturing tolerances (EU Legislation allows 5% tolerance). **Payload** figures do not allow for the weight of the driver, or any passengers, which should therefore be deducted from the figures shown. UK and Ireland Specification adds radio and deadlocks to base vehicle adding 10kg. Sportive specification adds a further 45kg to Sportive L1 Panel Van and 30kg to Sportive L2 Panel Van. **Gross plated weights** (including axle weights) quoted on the vehicle plate are to UK and Ireland plated weight specification and must never be exceeded. **Roof load** should not exceed 100kg on H1 models including the weight of the roof rack/carrier. H2 models are not permitted to carry roof loads.

# L2 H1 PANEL VAN

## EXTERIOR DIMENSIONS MM (INCHES)

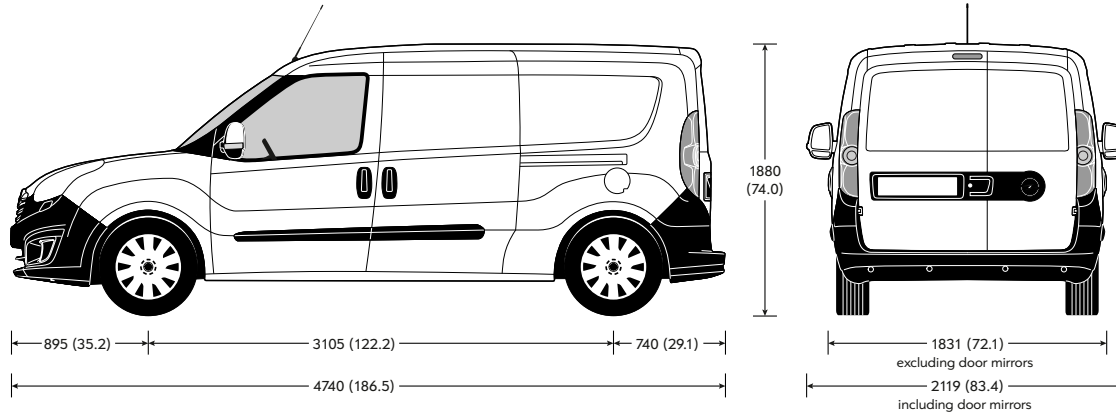

Height shown unladen.

## LOADSPACE DIMENSIONS MM (INCHES)

### Maximum load length

Panel Van	2170 (85.4)
-----------	-------------

### Maximum load width

At widest point	1714 (67.5)
Between wheel arches	1230 (48.4)

### Maximum load height

Maximum height	1305 (51.4)
----------------	-------------

### Rear and side load door(s)

Rear door aperture height	1250 (49.2)
Rear door aperture width	1231 (48.5)
Side door aperture height	1175 (46.2)
Side door aperture width	700 (27.5)

### Loading height

Unladen	545 (21.4)
---------	------------

## LOADSPACE VOLUMES CU.M (CU.FT.)

Panel van	4.2 (148)
-----------	-----------

## WEIGHTS AND TOWING DATA

	Plated weights and kerbweight kg				Payload kg	Towing weights Trailer with brakes (without brakes) kg	Plated Gross Combination Weights (GCW) kg
	Front axle Plated	Rear axle Plated	GVW	Total Minimum Mass			
<b>L2 H1 Panel Van</b>							
2300 1.3CDTi (95PS)	1120	1450	2385	1460	990	1000 (500)	3385
2300 1.6CDTi (105PS)	1200	1450	2458	1505	1018	1300 (500)	3500

**Note: Minimum Mass** ('Mass in running order' on Certificate of Conformity and 'Mass in Service' on V5C form) is defined according to European Type Approval and include all fluids, tools, 90% fuel load and driver (75kg). It is minimum mass for this variant and does not consider local specification/trim. Weights are also subject to manufacturing tolerances (EU Legislation allows 5% tolerance). **Payload** figures do not allow for the weight of the driver, or any passengers, which should therefore be deducted from the figures shown. UK and Ireland Specification adds radio and deadlocks to base vehicle adding 10kg. Sportive specification adds a further 45kg to Sportive L1 Panel Van and 30kg to Sportive L2 Panel Van. **Gross plated weights** (including axle weights) quoted on the vehicle plate are to UK and Ireland plated weight specification and must never be exceeded. **Roof load** should not exceed 100kg on H1 models including the weight of the roof rack/carrier. H2 models are not permitted to carry roof loads.

# L2 H1 GLAZED CREW VAN

## EXTERIOR DIMENSIONS MM (INCHES)

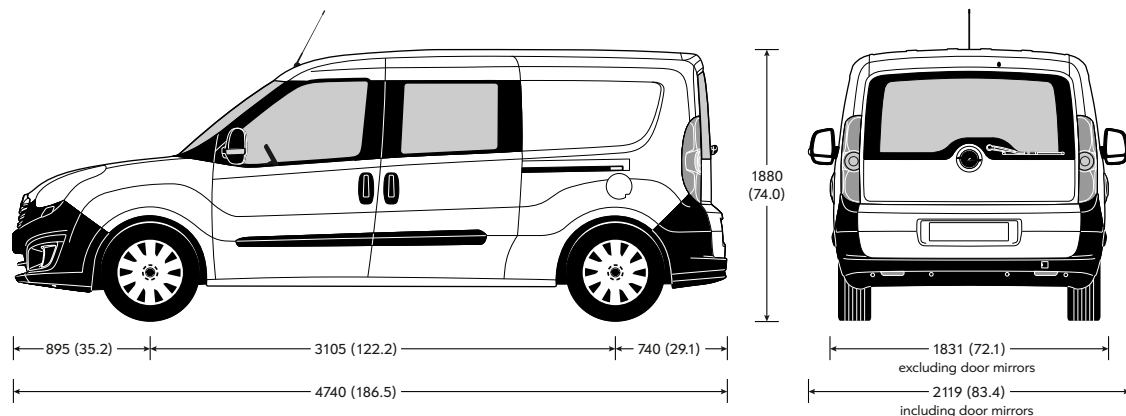

Height shown unladen.

## LOADSPACE DIMENSIONS MM (INCHES)

### Maximum load length

Crew Van with seats up	1341 (52.8)
Crew Van with seats down	1750 (68.9)

### Maximum load width

At widest point	1714 (67.5)
Between wheel arches	1230 (48.4)

### Maximum load height

Maximum height	1305 (51.4)
----------------	-------------

### Rear and side load door(s)

Rear door aperture height	1250 (49.2)
Rear door aperture width	1231 (48.5)
Side door aperture height	1175 (46.2)
Side door aperture width	700 (27.5)

### Loading height

Unladen	545 (21.4)
---------	------------

## LOADSPACE VOLUMES CU.M (CU.FT.)

Crew Van with seats up (to top of seats)	1.0 (35.3)
Crew Van with seats up (to roof)	1.9 (67.1)

## WEIGHTS AND TOWING DATA

	Plated weights and kerbweight kg				Payload kg	Towing weights Trailer with brakes (without brakes) kg	Plated Gross Combination Weights (GCW) kg
	Front axle Plated	Rear axle Plated	GVW	Total Minimum Mass			
<b>L2 H1 Glazed Crew Van</b>							
2300 1.3CDTi (95PS)	1120	1310	2254	1505	764	1000 (500)	3254
2300 1.6CDTi (105PS) Start/Stop	1200	1310	2349	1600	764	1300 (500)	3500

**Note: Minimum Mass** ('Mass in running order' on Certificate of Conformity and 'Mass in Service' on V5C form) is defined according to European Type Approval and include all fluids, tools, 90% fuel load and driver (75kg). It is minimum mass for this variant and does not consider local specification/trim. Weights are also subject to manufacturing tolerances (EU Legislation allows 5% tolerance). **Payload** figures do not allow for the weight of the driver, or any passengers, which should therefore be deducted from the figures shown. UK and Ireland Specification adds radio and deadlocks to base vehicle adding 10kg. Sportive specification adds a further 45kg to Sportive L1 Panel Van and 30kg to Sportive L2 Panel Van. **Gross plated weights** (including axle weights) quoted on the vehicle plate are to UK and Ireland plated weight specification and must never be exceeded. **Roof load** should not exceed 100kg on H1 models including the weight of the roof rack/carrier. H2 models are not permitted to carry roof loads.

# L2 H2 PANEL VAN

## EXTERIOR DIMENSIONS MM (INCHES)

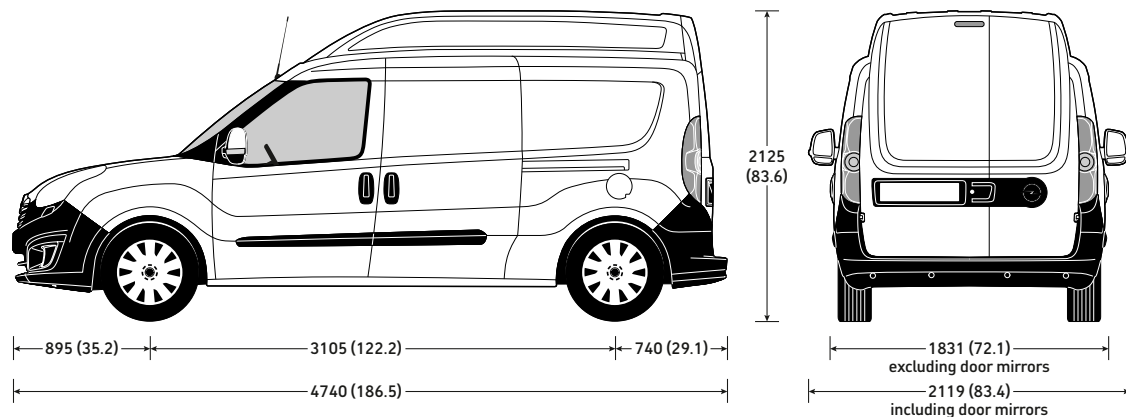

Height shown unladen.

## LOADSPACE DIMENSIONS MM (INCHES)

### Maximum load length

Panel Van	2170 (85.4)
-----------	-------------

### Maximum load width

At widest point	1714 (67.5)
-----------------	-------------

Between wheel arches	1230 (48.4)
----------------------	-------------

### Maximum load height

Maximum height	1550 (61.0)
----------------	-------------

### Rear and side load door(s)

Rear door aperture height	1455 (57.2)
---------------------------	-------------

Rear door aperture width	1231 (48.5)
--------------------------	-------------

Side door aperture height	1175 (46.2)
---------------------------	-------------

Side door aperture width	700 (27.5)
--------------------------	------------

### Loading height

Unladen	545 (21.4)
---------	------------

## LOADSPACE VOLUMES CU.M (CU.FT.)

Panel Van	5.0 (177)
-----------	-----------

## WEIGHTS AND TOWING DATA

### Plated weights and kerbweight kg

	Total				Payload kg	Towing weights Trailer with brakes (without brakes) kg	Plated Gross Combination Weights (GCW) kg
	Front axle Plated	Rear axle Plated	GVW	Minimum Mass			
<b>L2 H2 Panel Van</b>							
2300 1.6CDTi (105PS) Start/Stop	1200	1450	2488	1535	1018	1300 (500)	3500

**Note:** **Minimum Mass** ('Mass in running order' on Certificate of Conformity and 'Mass in Service' on V5C form) is defined according to European Type Approval and include all fluids, tools, 90% fuel load and driver (75kg). It is minimum mass for this variant and does not consider local specification/trim. Weights are also subject to manufacturing tolerances (EU Legislation allows 5% tolerance). **Payload** figures do not allow for the weight of the driver, or any passengers, which should therefore be deducted from the figures shown. UK and Ireland Specification adds radio and deadlocks to base vehicle adding 10kg. Sportive specification adds a further 45kg to Sportive L1 Panel Van and 30kg to Sportive L2 Panel Van. **Gross plated weights** (including axle weights) quoted on the vehicle plate are to UK and Ireland plated weight specification and must never be exceeded. **Roof load** should not exceed 100kg on H1 models including the weight of the roof rack/carrier. H2 models are not permitted to carry roof loads.