Contents

Introduction.....	0-1
Tipper	1-1
Dropside	2-1
Double cab	3-1
Auxiliary heating systems	4-1

Introduction

This manual contains supplementary information regarding the operation and use of specific conversions available for your vehicle. This manual should be used in conjunction with the vehicle Owner's Manual.

You must always comply with the specific laws of the country that you are travelling through. These laws may differ from the information in this manual.

When instructed to consult a workshop, we recommend that you consult an Opel Service Partner. All Opel Service Partners offer first-class service at reasonable prices.

You will receive quick, reliable and individual service.

Experienced mechanics, trained by Opel, work according to specific Opel instructions.

This manual should always be kept together with the Owner's Manual and Service Booklet in the vehicle: Ready to hand in the glove compartment.

Make use of this manual:

- Yellow arrows in the illustrations serve as points of reference or indicate some action to be performed.
- Black arrows in the illustrations indicate a reaction or a second action to be performed.
- Directional data, e.g. left or right, or front or back, in the descriptions always relates to the direction of travel.
- Page references are indicated with ↗. ↗ means "see page".

Warning, Caution

Vehicle passengers should be informed accordingly.

Warning

Text marked  **Warning** provides information on risk of accident or injury. Disregard of these instructions may result in injuries.

Caution

Text marked **Caution** provides information on possible damage to the vehicle. Disregard of these instructions may lead to vehicle damage.

Tipper

Loading	1-1
Tailboard	1-2
Sideboards.....	1-3
Lashing points.....	1-3
Tipper operation.....	1-4
Isolation switch	1-4
Safety cable	1-6
Safety prop	1-6
Cleaning.....	1-7
Owner's checks.....	1-7
Technical data	1-8
Maintenance	1-10
Confirmation of hydraulic fluid change.....	1-11

Loading¹⁾

The three-way tipper is designed for carrying bulk materials that can be discharged by tipping.

The three-way tipper is not designed for carrying people or unsuitable/unsafe materials.

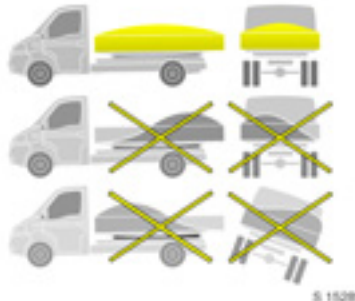

- Ensure the vehicle tailboard and sideboards are securely closed before loading.

- Load the vehicle evenly, distributing the load across the body.
- Secure any solid loads with additional lashing equipment.
- Place loads from the minimum practicable height. Do not drop loads onto the tipper body.
- Do not overload the tipper body.
- Ensure the load will not fall out or endanger other road users.
- Do not drive with the body tipped.
- Do not drive with the tailboard or sideboards down.
- Do not attempt to tip loads from the body when body sides or tailboard are closed.

¹⁾ Observe the national regulations on securing loads.

Tailboard

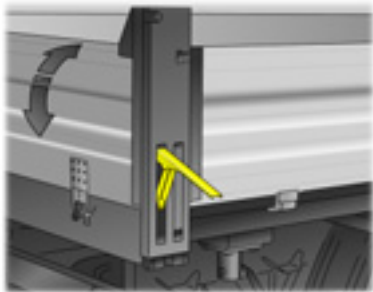

Opening

To open the tailboard, pull up the release levers to disengage the locks and lower the tailboard fully.

To close the tailboard, raise the tailboard and push firmly into position. Push down the release levers ensuring locks engage fully.

Swinging

⚠ Warning

Before using the swinging tailboard, check the release levers are securely latched on both sides.

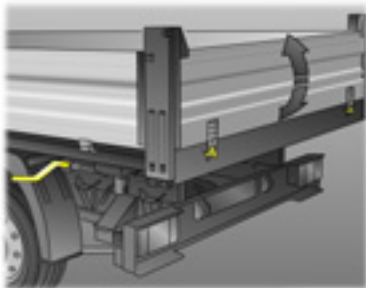

To release, pull the remote lever located on the rear left side of the body. The tailboard is disengaged and will swing from its upper hinges.

To lock, engage the lower tailboard hinges and push the remote lever to lock position. Check the tailboard is secure.

Removing

⚠ Warning

Two people are required to carry out this operation.

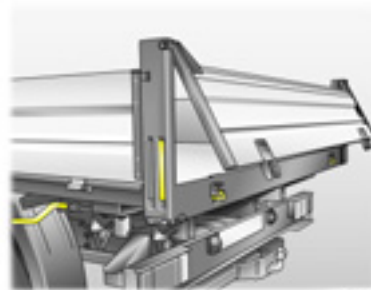

Pull the remote lever located on the rear left side of the body. The tailboard is disengaged and will swing on its upper locks.

With the help of an assistant, support the tailboard weight and pull up the release levers. Remove the tailboard from the tipper body.

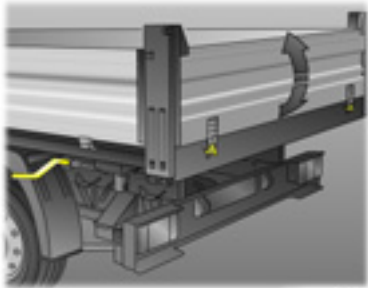

© 15287

To reinstall: Install the tailboard onto the upper hinges and push down the release levers ensuring locks engage fully.

Insert the tailboard into the lower hinges and push the remote lever to lock position.

Check the tailboard is secure.

Sideboards

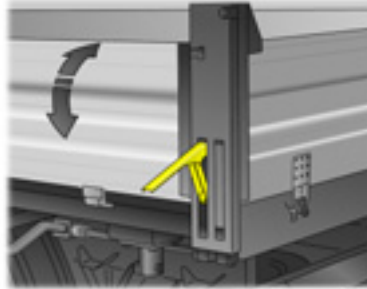

© 15279

To open, pull up the release levers to disengage the locks. Lower the sideboard fully.

To close, raise the sideboard and push firmly into position. Push down the release levers ensuring locks engage fully.

Lashing points



© 15294

Secure heavy objects with lashing straps attached to the lashing points.

Caution

When loading heavy or bulk items, the lashing point eyes must be flush with the body floor to avoid causing any damage.

The maximum force applied to the lashing point eyes should not exceed 5000N at 30°.

1-4 Tipper

Tipper operation



Warning

The operator must remain at the control to ensure tipping and lowering are performed correctly.

Do not allow anyone in or onto the tipper body whilst operating the tipper.

Ensure the vehicle is on level ground and that the tipper body can be raised to the maximum height without fouling overhead obstructions.

The tipper body has two locking pins with each pin having a locator on its upper edge. The locking pins are used to obtain any one of the three tipping positions.

Caution

The tipper must not be operated with locking pins incorrectly installed.

Pins installed diagonally opposite or in both front pivot positions will result in damage if tipping is attempted!

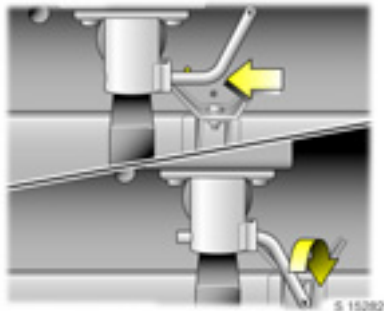

To insert locking pin into pivot, ensure the handle and locator are facing up. Rotate the locking pin away from the upright position to ensure the pin is secured.

Isolation switch

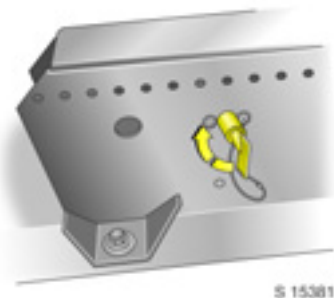

The system must be activated using the isolation switch located on the left side tipper frame behind the cab. Insert and turn the isolator key in the switch.

When the tipper is not in use, turn the isolator key to the off position and remove it.

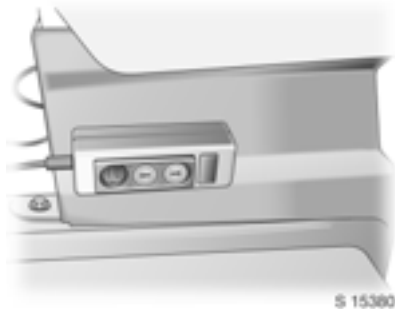

Raising and lowering the tipper

The tipper is operated using the remote control located on the seat base.



The remote control enables the user to supervise the operation of the tipper from outside the vehicle.

The remote control is magnetic and can be stored on the seat base when not in use.

1. With the isolation switch activated, depress the  switch on the remote control to raise; or the  switch

switch to lower. The tipper can be stopped at any time by releasing the switch.

2. The tipper body will cease moving automatically when it reaches maximum height.

An acoustic signal will sound to indicate when the tipper control is activated.

Tipping to the rear

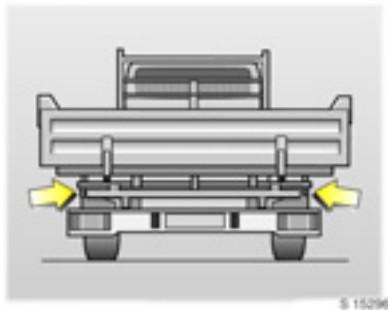

Fully insert locking pins into the left and right-hand rear pivots, ensuring the handle and locator are facing up.

Rotate the locking pin away from the upright position to ensure the pin is secured.

Tipping to the side

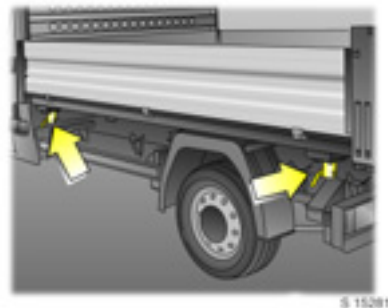

To tip to the left side, fully insert locking pins into the front and rear left-hand pivots. Ensure the handle and locator on both locking pins are facing up. Rotate both locking pins away from the upright position to ensure the locking pins are secured.

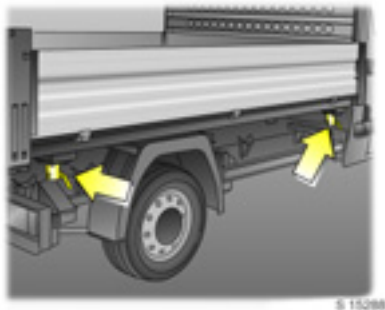

To tip to the right side, fully insert locking pins into the front and rear right-hand pivots. Ensure the handle and locator on both locking pins are facing up. Rotate both locking pins away from the upright position to ensure the locking pins are secured.

Safety cable

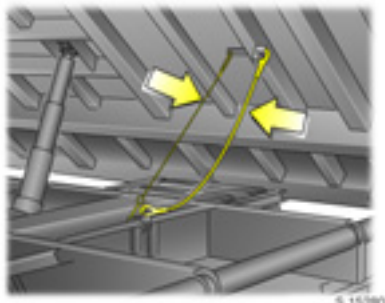

The safety cable attached to the tipper body prevents the tipper body being raised too far. Should a safety cable become damaged it must be replaced immediately. Seek the assistance of a workshop.

Safety prop

The safety prop is located under the left-hand side of the tipper body and is provided only to assist in supporting the tipper body when tipped to the rear, for carrying out visual inspection of the vehicle components.

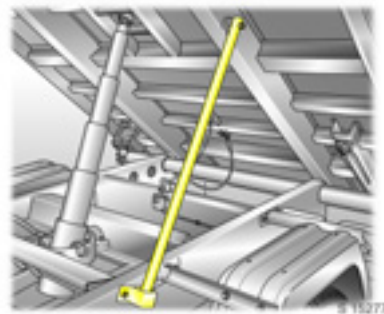

Using the safety prop:

1. Prepare the tipper body for tipping to the rear.
2. Raise the tipper body sufficiently enough to access the safety prop.
3. Release the safety prop from the underside of the tipper body and fold down.
4. Swing the safety prop downwards to align with support.
5. Carefully guide the safety prop into the support position then lower the tipper body.

Stowing the safety prop:

1. Raise the tipper body sufficiently to release the safety prop from its support.
2. Fold the safety prop into the stowed position and secure in the spring clip.
3. Lower the tipper body.

Cleaning

Dirt or mud which remains dry on the body may become abrasive and can damage paint, seals, locks and hinges.

Clean the following parts if they become contaminated with dirt:

- Sideboard and tailboard locking latches and hinges.
- Tipper body pivot pins and locating holes.

Caution
Do not spray high-pressure water directly at the hydraulic seals, pump, reservoir, hydraulic ram ball joints, or guide clamps.

After cleaning, check and if necessary lubricate the components listed in the owner's checks.

Owner's checks

Check regularly the following items.

Every week:

- Lubricate the tailboard and sideboard locking latches with high-pressure grease and check for correct operation.
- Lubricate the tailboard and sideboard hinges with lube oil and check for correct operation.

Every month:

- Visually check the subframe mountings, the safety cables and the hydraulic system. If any of the components appear loose, defective or leaking, seek the assistance of a workshop to rectify the cause of the fault.

Every 6 months:

- Lubricate the tipper body pivots and the safety prop hinge with high-pressure grease.

⚠ Warning
Do not venture under the tipper body when raised.

Technical data

The technical data is determined in accordance with European Community standards. We reserve the right to make modifications.

Specifications in the vehicle documents always have priority over those stated here.

Vehicle identification

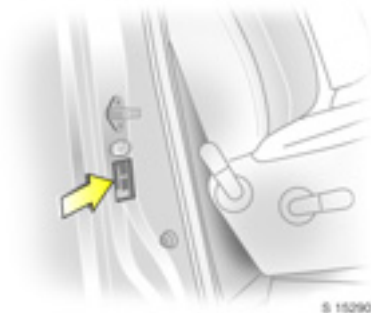

The Gross Vehicle Weight and Gross Train Weight can be found on the vehicle identification plate, which is located on the right-hand door pillar.

Payload (approx. kg)

Model	Wheelbase	GVW	Kerb weight ¹⁾²⁾
Chassis cab	Medium	3500	2276-2438
Crew cab	Long	3500	2429-2592

¹⁾ In accordance with EC directive of base model, including assumed weights of driver (75 kg) and all fluids (tank 90% full).

²⁾ Depending on optional equipment.

Dimensions (approx. mm)

	Chassis cab	Crew cab
Wheelbase	Medium	Long
Overall length	5642	5986
Overall height (unladen)		
without cab protection	2182	2182
with cab protection ✳	2552	2552
maximum height (with conversion)	3500	3500
Turning circle diameter (m) - kerb to kerb	13.75	15.20
- wall to wall	14.11	15.68

Maintenance

In addition to the standard maintenance for your vehicle, the tipper body requires further checks and operations to be performed. Seek the assistance of a workshop.

Hydraulic fluid change

It is necessary to change the hydraulic fluid annually, or every 1500 tipping operations, whichever occurs first.

Changing the hydraulic fluid:

1. Ensure the body is fully lowered.
2. Remove filler cap from hydraulic fluid reservoir.
3. Remove hydraulic fluid from reservoir using a suitable fluid extractor.
4. Replace hydraulic fluid ensuring fluid level is between MIN and MAX.
5. Replace filler cap and secure.

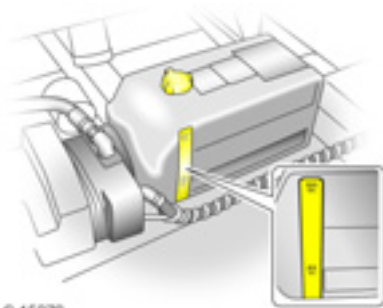

S 15379

Bleeding the hydraulic system:

To bleed the hydraulic system, raise then lower tipper body, then recheck the fluid level.

Ensure the fluid level is at MIN level on reservoir when the tipper body is in its maximum raised position.

Caution

Do not attempt to operate the system without hydraulic fluid.

Hydraulic fluid specification	Capacity
HM or HV to ISO VG32 (-20°C to +60°C)	7 litres

Confirmation of hydraulic fluid change

Confirmation of the hydraulic fluid change must be verified on the following stamping spaces.

Date:

Stamp and signature of Opel Service Partner

Date:

Stamp and signature of Opel Service Partner

Date:

Stamp and signature of Opel Service Partner

Date:

Stamp and signature of Opel Service Partner

1-12 Tipper

Date:

Date:

Date:

Stamp and signature of
Opel Service Partner

Stamp and signature of
Opel Service Partner

Stamp and signature of
Opel Service Partner

Date:

Date:

Date:

Stamp and signature of
Opel Service Partner

Stamp and signature of
Opel Service Partner

Stamp and signature of
Opel Service Partner

Dropside

Loading	2-1
Sideboards.....	2-1
Tailboard	2-2
Step	2-2
Lashing points.....	2-2
Cleaning.....	2-3
Owner's checks.....	2-3
Technical data	2-3

Loading¹⁾

The dropside body is not designed for carrying people or unsuitable/unsafe materials.

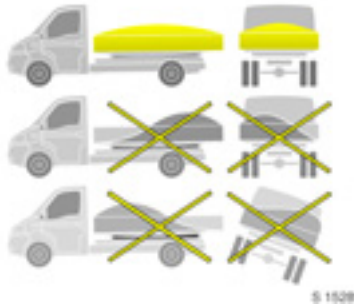

- Ensure the vehicle tailboard and sideboards are securely closed before loading.
- Load the vehicle evenly, distributing the load across the body.
- Secure any solid loads with additional lashing equipment.

¹⁾ Observe the national regulations on securing loads.

- Place loads from the minimum practicable height. Do not drop loads onto the body floor.
- Do not overload the dropside body.
- Ensure the load will not fall out or endanger other road users.
- Do not drive with the tailboard or sideboards down.

Sideboards

To open, release both side board levers by pushing the thumb button down and pulling the lever out.



2-2 Dropside

Swing the lever up until it contacts the body and the lock pin becomes visible. Lower the sideboard carefully.



To close, raise the sideboard and push firmly against the body. Swing the lever down into its recess until an audible click is heard. Check the sideboard is secure.

Tailboard

To open, release both tailboard levers and lower the tailboard carefully.

To close, raise the tailboard and push firmly against the body. Swing the lever down into its recess until an audible click is heard. Check the tailboard is secure.

Step

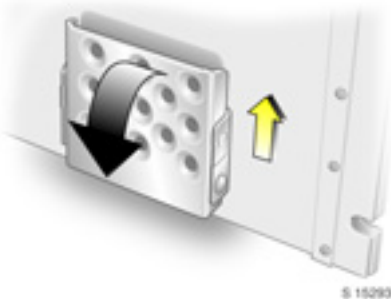

To lower the step with the tailboard down, lift the step plate up in the mounting bracket and swing it down.

To stow the step, swing the step plate up into the vertical position and slide it down into the mounting bracket.

Lashing points



Secure heavy objects with lashing straps attached to the lashing points.

Caution

When loading heavy or bulk items, the lashing point eyes must be flush with the body floor to avoid causing any damage.

The maximum force applied to the lashing point eyes should not exceed 5000N at 30°.

Cleaning

Dirt or mud which remains dry on the body may become abrasive and can damage paint, seals, locks and hinges.

Clean the following parts if they become contaminated with dirt:

- Sideboard and tailboard locking latches and hinges.

After cleaning, check and lubricate the latches and hinges as necessary.

Owner's checks

It is essential that the owner regularly checks the following items.

Every week:

- Check the tailboard and sideboard hinges for correct operation.

Every month:

- Visually check the subframe mountings. If any fixings appear loose or are missing, seek the assistance of a workshop to rectify the cause of the fault.

Technical data

The technical data is determined in accordance with European Community standards. We reserve the right to make modifications.

Specifications in the vehicle documents always have priority over those stated here.

Vehicle identification

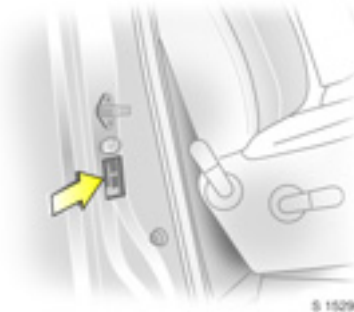

The Gross Vehicle Weight and Gross Train Weight can be found on the vehicle identification plate, which is located on the right-hand door pillar.

2-4 Dropside

Payload (approx. kg)

Model	Wheelbase	GVW	Kerb weight ¹⁾²⁾
Chassis cab	Medium	3500	1861-2012
	Long	3500	1909-2074
Crew cab	Long	3500	2044-2201

¹⁾ In accordance with EC directive of base model, including assumed weights of driver (75 kg) and all fluids (tank 90% full).

²⁾ Depending on optional equipment.

Dimensions (approx. mm)

Wheelbase	Chassis cab		Crew cab
	Medium	Long	Long
Overall length	5680	6130	5995
Overall height (unladen)			
without cab protection	2200	2200	2195
with cab protection ✱	2290	2290	2285
Turning circle diameter (m) - kerb to kerb	13.75	15.20	15.20
- wall to wall	14.11	15.68	15.68

Double cab

Introduction	3-1
Technical data	3-3

Introduction

The double cab uses an additional rear bench seat to provide increased seating for up to six people. The rear loadspace area is separated from the passenger compartment by a partition wall.

Additional loadspace under the rear seat provides increased storage in the load compartment.

3-2 Double cab

Child restraint systems *

The table shows permissible locations for installing a child restraint system. Refer to Owner's Manual for further information.

Rear seats

Group, weight and age class	Facing direction	Rear bench seat	
		Outer	Centre
0: up to 10 kg or approx. 10 months 0+: up to 13 kg or approx. 2 years	Rearward	X	X
I: 9 to 18 kg or approx. 8 months - 4 years	Forward	X	X
II: 15 to 25 kg or approx. 3 - 7 years III: 22 to 36 kg or approx. 6 - 12 years	Forward	X	X

X = Seat position not suitable for children of this mass group.

Technical data

The technical data is determined in accordance with European Community standards. We reserve the right to make modifications.

Specifications in the vehicle documents always have priority over those stated here.

Vehicle identification



The Gross Vehicle Weight and Gross Train Weight can be found on the vehicle identification plate, which is located on the right-hand door pillar.

3-4 Double cab

Payload (approx. kg)

Model	Wheelbase	GVW	Kerb weight ¹⁾²⁾
Double cab	Medium	3500	2004 - 2019
		3500	2012 - 2026 ³⁾
	Long	3500	2047 - 2061
		3500	2055 - 2069 ³⁾

¹⁾ In accordance with EC directive of base model, including assumed weights of driver (75 kg) and all fluids (tank 90% full).

²⁾ Depending on optional equipment.

³⁾ Easytronic transmission.

Loadspace dimensions (approx. mm)

Wheelbase	Medium	Long
Maximum length at load floor	2730	3230
Maximum length behind rear seats	2160	2660
Maximum width	1764	1764
Maximum height	1912 2146 ¹⁾	1912 2146 ¹⁾

¹⁾ High roof version.

Auxiliary heating systems

Coolant heater	4-1
Air heater	4-3
Remote control unit ✱	4-6

Coolant heater

The Webasto engine-independent, fuel-powered coolant heater, located under the vehicle, provides rapid heating of the engine coolant to enable heating of the vehicle interior without running the engine. It will also help the engine to reach operational temperature more quickly.

The heater can be programmed to start at a specific time or switched on for immediate use.

The heater is controlled with a control unit on the instrument panel or with a radio remote control ✱.

Before switching the heater on or programming heating operation, turn the temperature switch on the heating and ventilation system to the red zone and set fan to position **2**.

When the heater unit is on, fuel consumption increases. Switch off the unit whenever it is not required. The heater will cease to operate if the vehicle fuel level drops too low.

The heater unit stops automatically after a maximum 1 hour of continuous use. The fuel supply to the heater is cut-off.

To ensure efficient performance, the heater must be operated briefly once a month.

If the heater does not start when switched on, switch it off and back on again. If it still does not start, seek the assistance of a workshop.

Warning

Do not operate the heater in an enclosed space and ensure it is switched off when refuelling!

The additional exhaust pipe on the side of the vehicle becomes very hot during use of the heater.

Refer to the supplied instructions for the heater unit for further information.

Manual control unit

The heater control unit is located on the instrument panel.

The heater unit can be switched on for immediate use (one-off mode) and the timer function * (programmed mode) set using the four buttons on the control unit.

The control unit can be used to programme up to 3 preset departure times * during 24 hours.



1 Back button

Adjusts values.

Switches on time display.

2 Display

Display of settings and status.

3 Next button

Adjusts values.

Switches on time display.

4 Set button

Switches on presetting mode.

Confirms inputs.

5 Heating button

Switches heater on/off.

Switching heater on for immediate use

Press the heating button to switch the heater on: the flame symbol and the heating duration appears in the display. Heating duration disappears after a brief delay.

With heater unit switched on, press the back or next button to change heating duration for this use of the heater only. The value can be set from 10 to 60 minutes.

Switching heater off

Press the heating button again to switch heating off: the flame symbol extinguishes.

Programming departure times

Press the set button until the preset time for memory location 1 appears in the display.

■ The flame symbol and 1 flashes.

Change the preset time using the back or next button and/or press set.

■ The flame symbol and 2 flashes.

Change the time and/or press set.

■ The flame symbol and 3 flashes.

Change the time and/or press set.

The preset departure times are stored and the display disappears.

Programming heating duration

Press and hold the set button and press the back or next button.

■ The time and the clock symbol are displayed.

Release the set button.

Press and hold the set button again and press the back or next button. Then release the set button.

- The heating duration is displayed and the flame symbol flashes.

Change heating duration using the back or next button. The value can be set from 10 to 60 minutes. Press set to confirm.

The preset heating duration for programmed mode is stored and the display disappears.

Activating departure times

Departure times must be activated individually. Only one departure time can be activated at a time.

Press the set button until the desired departure time and memory location is displayed. After a brief delay, the memory location to be activated flashes in the display along with the flame symbol, until the heater starts.

Deleting departure times

While the next preset memory location to be activated is flashing in the display along with the flame symbol, press the set button.

- The flame symbol and 1, 2 or 3 extinguishes.

Resetting

If the power supply is interrupted or the battery voltage is too low, the current time and all programmed departure times are lost: The unit will need to be reset.

To reset time: With heater off, press and hold the set button, press the back or next button, then release set.

- Time of day is displayed and the clock symbol flashes.

Set the time using the back or next button and press set. The time is stored and the display disappears.

Air heater

The Webasto engine-independent auxiliary air heater, located under the vehicle, provides additional heating for the rear passenger compartment during driving and while the vehicle is parked.

The heater can be programmed to start at a specific time or switched on for immediate use.

The heater is controlled with a control unit on the instrument panel or with a radio remote control ✱.

When the heater unit is on, fuel consumption increases. Switch off the unit whenever it is not required. The heater will cease to operate if the vehicle fuel level drops too low.

The heater unit stops automatically after a maximum 2 hours of continuous use.

To ensure efficient performance, the heater must be operated briefly once a month.

4-4 Auxiliary heating systems

If the heater does not start when switched on, switch it off and back on again. If it still does not start, seek the assistance of a workshop.

Warning

Do not operate the heater in an enclosed space and ensure it is switched off when refuelling!

The additional exhaust pipe on the side of the vehicle becomes very hot during use of the heater.

Refer to the supplied instructions for the heater unit for further information.

Manual control unit

Heater settings and adjustment are made using the control panel located on the instrument panel.

The heater unit can be switched on for immediate use (one-off mode) and the timer function * (programmed mode) set using the buttons on the control unit.

The control unit can be used to programme up to 3 preset departure times *, either during one day or over one week.

The temperature of the rear passenger compartment can be adjusted to the desired value using the rotary knob.



- 1 Display
Display of settings and status.
- 2 Temperature knob
Changes temperature.
- 3 Next button

Selects display options and adjusts values.

4 Back button

Selects display options and adjusts values.

5 Heating button

Switches heating on/off.

6 Program button

Switches on presetting mode.

7 Clock button

Switches on clock mode.

Switching heater on for immediate use

Press the heating button to switch the heater on: the button illuminates and the heating symbol  appears in the display.

With heater unit switched on and the ignition off, press the back or next button to change heating duration for this use of the heater only. The value can be set from 10 to 120 minutes.

Switching heater off

Press the heating button again to switch heating off: the light in the button and the heating symbol  extinguishes.

Programming departure times

Press the program button.

- Preset memory location 1, 2 or 3 flashes.

Select desired program memory location by repeatedly pressing the program button, and set departure time using the back or next button.

- Weekday flashes.

Set the weekday using the back or next button. When flashing ceases, the time and weekday are set.

Repeat procedure to programme the other preset memory locations.

Programming heating duration

With heater unit switched off, press and hold the back button for approx. 3 seconds.

- Heating duration flashes.

Change heating duration for programmed mode using the back or next button. The value can be set from 10 to 120 minutes.

Activating departure times

Departure times must be activated individually. Only one departure time can be activated at a time.

Press the program button until the desired memory location flashes.

When flashing ceases, the memory location to be activated appears in the display.

Deleting departure times

Press the program button.

- Preset memory location 1, 2 or 3 flashes.

Select desired program memory location by pressing the program button and erase departure time by repeatedly pressing the program button until the time is displayed instead of the memory location.

Resetting

If the power supply is interrupted or the battery voltage is too low, the current weekday and time and all programmed departure times are lost: The unit will need to be reset.

To reset weekday and time: Press and hold the clock button for approx. 2 seconds.

- Time of day flashes.

Set the time using the back or next button.

- Weekday flashes.

Set the weekday using the back or next button.

When flashing ceases, the time and weekday are set.

Air vents

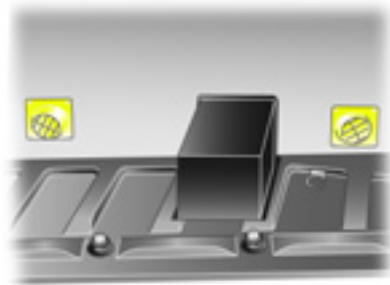

S 17497

Two adjustable air vents are located on the lower part of the sidewall cover in the rear passenger compartment.

Remote control unit *



S 17471

The heater can be started and stopped using the remote control unit. The remote control has a maximum range of 600 metres. The range will reduce due to environmental conditions.

Press ON to switch the heater on; the LED on the remote control flashes until the heater is switched off or the programmed heating duration elapses. Press OFF to switch the heater off again; LED extinguishes.

Refer to the supplied instructions for the heater and the remote control unit for further information.

Battery replacement

Replace the batteries (MN21 or equivalent) when the range of the remote starts to become reduced.

Open the rear cover and replace batteries. Ensure the new batteries are installed correctly, with the positive (+) sides facing the positive terminals. Replace cover.

Dispose of old batteries in accordance with environmental regulations.